



This small siren operates with a hand crank and produces a good sound and adjustable pitch control

Typical applications:
Commonly used as a backup alarm when there is a power failure or applications in remote areas where no electricity is available. Also used on blasting sites





 HAND OPERATED SIRENS

Sirenco H100

SPECIFICATIONS

OPERATING METHOD	Hand operated
SOUND OUTPUT	105dB(A) at 1m
SOUND FREQUENCY	1250 Hz
APP. RANGE	500m in ideal condition (Please refer to dB chart)
WEIGHT	1.2kg
PACKING DIMENSIONS	155mm x 155mm x 160mm

NOTES | Available Colours: Red & green. Available material: Metal

PRODUCT CODES

Code	SSH100M	SSH100B																	
Detail	H100	Bag																	

TECHNICAL DRAWINGS

All dimensions in mm

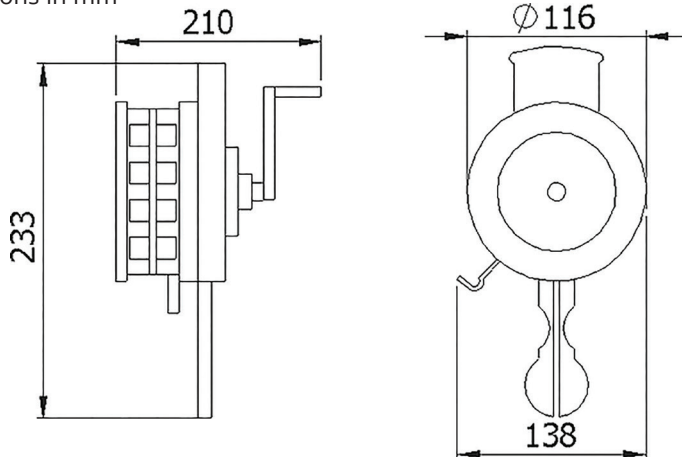

OPTIONAL EXTRAS

Carry Bag



Base plate conversion

