

# Sirenco Hydraulic Siren

ELECTRONIC SOUNDERS, BELLS,  
HORNS & HOOTERS

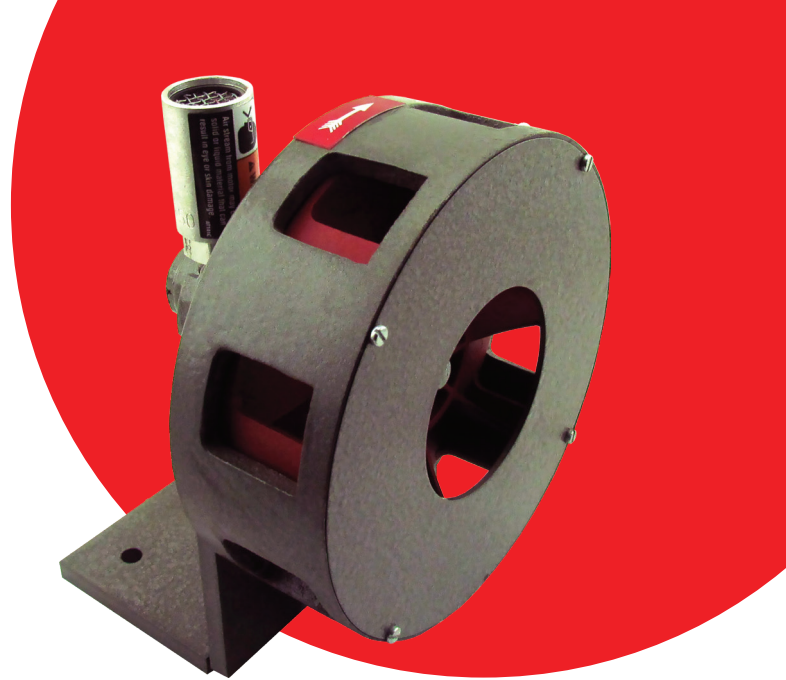

Robust aluminium siren with a hydraulic motor. Designed for applications where a siren is required and oil/hydraulic pressure is available, particularly where hydraulics is preferred to electronics in areas and where safety is paramount i.e. earth moving machines and other pneumatically operated equipment.



## SPECIFICATIONS

VOLTAGE	Oil/ Hydraulic pressure
SOUND OUTPUT	117dB(A) at 1m
SOUND FREQUENCY	500Hz
APP. RANGE	1500m in ideal condition (Please refer to dB chart)
MOTOR	Pneumatic motor
AIR PRESSURE	7bar or between 350 to 1000kpa
AIRFLOW	7bar (100psi) max
IP RATING	IP 44
WEIGHT	2kg
PACKING DIMENSIONS	270mm x 220mm x 220mm

NOTES |

## PRODUCT CODES

<b>Code</b>	SSHY150					
<b>Detail</b>	Hydraulic motor					

## TECHNICAL DRAWINGS

All dimensions in mm

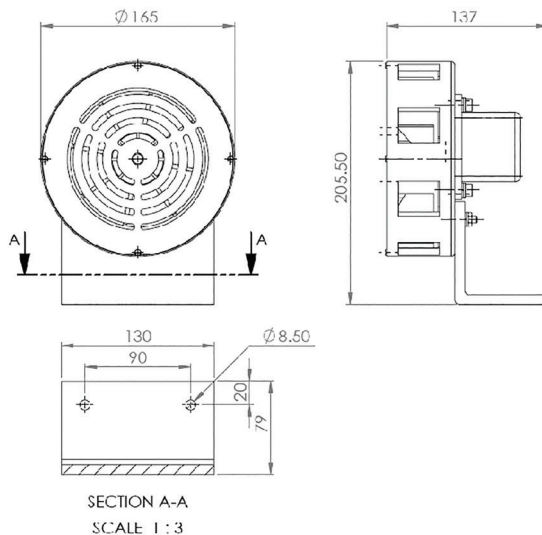

## OPTIONAL EXTRAS