

An outdoor weatherproof industrial siren made with a durable aluminium body and powerful continuous rated electric motor, available in 3 phase voltage. The very powerful low frequency sound output ensures a sound output of 140dB(A) at 1m. This is our largest siren available for single phase operation.

A reliable siren with a 5-year guarantee*

Typical applications:

Emergency and warning notification device at open cast mines, quarries, larger factories, and open areas like golf courses, airports, harbours, and prisons. Suitable for use as an emergency and warning notification device at indoor noisy environments.

LONG RANGE SIREN   

Sirencos 10S

SPECIFICATIONS

VOLTAGE	380VAC(3Φ) 525VAC(3Φ)
DUTY CYCLE	Continuous Rated
SOUND OUTPUT	140dB(A) at 1m
SOUND FREQUENCY	560Hz
APP. RANGE	10 000m in ideal condition (Please refer to dB chart)
MOTOR	4KW motor - 2875rpm
CURRENT CONSUMPTION	380V AC(3Φ) - 10A 525V AC(3Φ) - 6A
IP RATING	IP 55 (IP 65 or IP 56 available on request)
WEIGHT	75kg
PACKING DIMENSIONS	600mm x 600mm x 750mm

NOTES |

PRODUCT CODES

Code	SML1238	SML1252								
Detail	380V	525V								

TECHNICAL DRAWINGS

All dimensions in mm

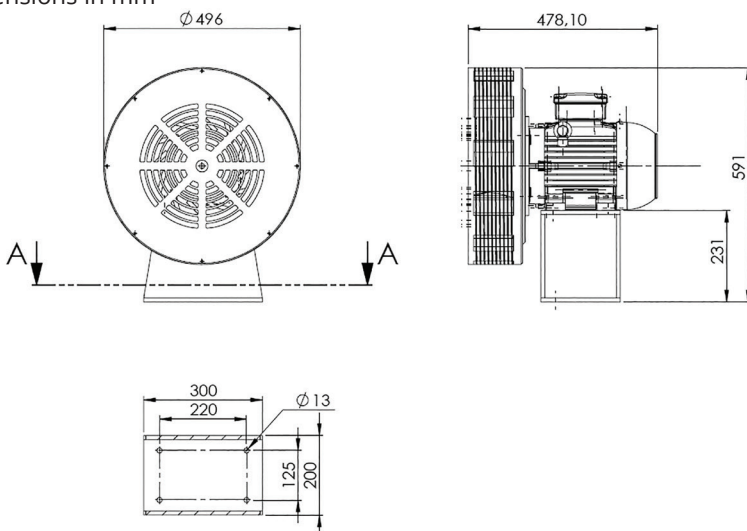

OPTIONAL EXTRAS

SHUTTER VALVE

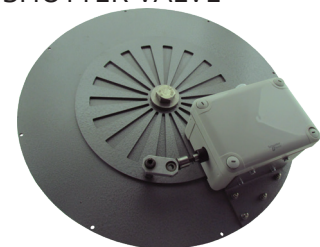

ANTI-ICING UNIT

